

POCLANE



PLX20U MINI EXCAVATOR



Model	: YANMAR 3TNV74F
Rated Power	: 12 kW/2400rpm
Operating Weight	: 1900kg
Bucket Capacity	: 0.04 cum

Technical Specifications

ENGINE

Model	YANMAR 3TNV74F
No. of cylinder	3
Max. Torque/Speed	49/1800N·m/rpm
Displacement	1L

HYDRAULIC SYSTEM

Max. Main Pump Flow	65 LPM
Main Safety Valve Pressure	20MPa

MAIN PERFORMANCE

Bucket Digging Force	17kN
Arm Digging Force	10kN
Max. Traction Force	19kN
Rotary Speed	9.5 r/min
Gradeability	58°
Ground Pressure	30kPa

REFILLING CAPACITIES & LUBRICATIONS

Fuel Tank	19L
Cooling System	5L
Engine Oil	3.7L
Hydraulic Oil Tank	20L

OPERATING WEIGHT & GROUND PRESSURE

Show Width	230mm
Ground Pressure	29kPa
Operating Weight	1800kg

DIMENSIONS

A Transport Length (arm lowered)	3570mm
B Overall Height (top of canopy)	2400mm
C Undercarriage Width (Retracted)	990mm
D Undercarriage Width (Extended)	1300mm
E Undercarriage Length	1587mm
F Upperbody Width (wero tail)	990mm

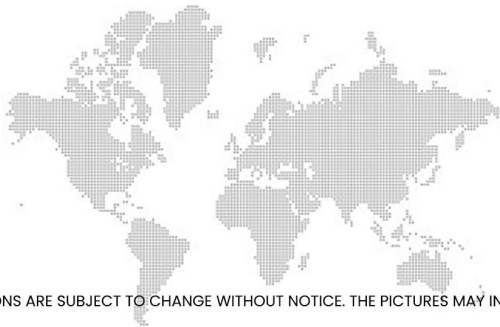

WORKING RANGE

A Max. digging height	3535mm
B Max. dumping height	2445mm
C Max. digging depth	2270mm
D Max. vertical digging depth	1910mm
E Max. digging reach	3910mm
F Max. digging reached at ground level	3845mm
G Min. Swing radius of work equipment	1495mm
H Max. lifting height of the blade	280mm
I Max. cutting depth of the blade	190mm

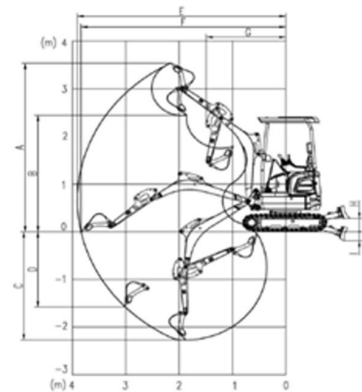

BUCKET

Type	Backhoe Bucket
Bucket Capacity	0.04 cum
Bucket Width	450mm

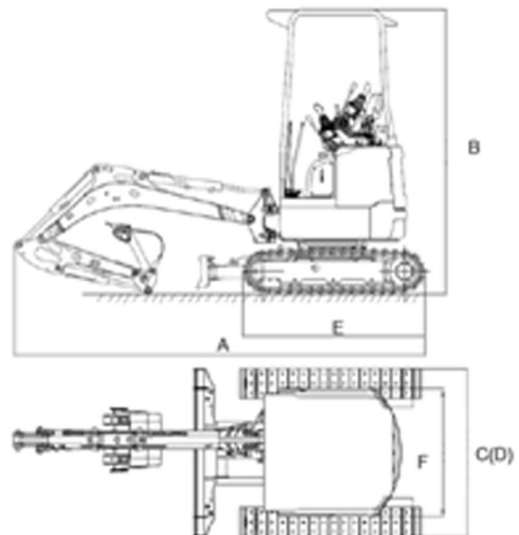

* THE SPECIFICATIONS ARE SUBJECT TO CHANGE WITHOUT NOTICE. THE PICTURES MAY INCLUDE OPTIONS. THE ACTUAL COLOR & APPEARANCE OF THE PRODUCT MAY DIFFER FROM WHAT IS SHOWN.



POCLANE

POCLANE CONSTRUCTION EQUIPMENT INDIA PVT LTD

ADDRESS: No. 8/110, GST ROAD, PALLAVARAM, CHENNAI 600 043, TAMILNADU, INDIA.

MOBILE: +9173582 55571 | +9186672 79007

EMAIL: sales@poclane.com | WEB: www.poclane.com



POCLANE